



US006865890B2

(12) **United States Patent**
Walker

(10) **Patent No.:** **US 6,865,890 B2**
(45) **Date of Patent:** **Mar. 15, 2005**

(54) **SOFTWARE SYSTEM FOR VERIFICATION OF GAS FUEL FLOW**

6,634,165 B2 * 10/2003 Tomlinson et al. 60/39.3
6,715,295 B2 * 4/2004 Gadde et al. 60/775

(76) Inventor: **Ronald Steven Walker**, 2825 Summer Swan Dr., Orlando, FL (US) 32825

(*) Notice: Subject to any disclaimer, the term of this patent is extended or adjusted under 35 U.S.C. 154(b) by 0 days.

(21) Appl. No.: **10/457,601**

(22) Filed: **Jun. 9, 2003**

(65) **Prior Publication Data**

US 2004/0016236 A1 Jan. 29, 2004

Related U.S. Application Data

(60) Provisional application No. 60/387,151, filed on Jun. 7, 2002.

(51) **Int. Cl.**⁷ **F02C 3/30**; F02C 9/48

(52) **U.S. Cl.** **60/773**; 60/775; 60/39.3; 60/39.55

(58) **Field of Search** 60/773, 775, 39.3, 60/39.53, 39.55

(56) **References Cited**

U.S. PATENT DOCUMENTS

- 4,160,362 A 7/1979 Martens et al.
- 4,259,835 A 4/1981 Reed et al.
- 4,305,129 A * 12/1981 Yannone et al. 30/39.281
- 4,308,463 A 12/1981 Giras et al.
- 4,687,946 A 8/1987 Jones
- 4,881,184 A 11/1989 Abegg, III et al.
- 5,307,619 A * 5/1994 McCarty et al. 60/775
- 5,761,895 A 6/1998 Chu et al.
- 5,794,446 A 8/1998 Earley et al.
- 6,226,974 B1 5/2001 Andrew et al.

OTHER PUBLICATIONS

GE Power Systems; Heavy-Duty Gas Turbine Operating and Maintenance Considerations; Hoeft, Janawitx and Keck, GE Energy Services, Atlanta, GA Jan. 2003.
Speedtronic Mark V Steam Turbine Control System; Kure-Jensen and Barker; GE Power Systems; 1996.
Speedtronic Mark V Steam Turbine Control System; Johnson, Miller and Ashley; GE Power Systems; undated.

* cited by examiner

Primary Examiner—Ted Kim

(74) *Attorney, Agent, or Firm*—Joseph T. Guy; Nexsen Pruet, LLC

ABSTRACT

(57)

A computerized system for accurate, independent verification of natural gas fuel flow in order to control H₂O injection flows. The H₂O is injected into a combustion system to control emissions. The system comprises: receiving gas turbine control parameters from a gas turbine control system; receiving control parameters from a megawatt transducer; calculating values based upon readings from said control system and said megawatt transducer; comparing said values to a megawatt reference curve; detecting an abnormal reading; starting a timing sequence during which said reading is monitored; transferring NO_x and H₂O water injection control to a megawatt module at completion of said timing sequence; alerting operator said transfer; allowing for return of control to said gas turbine control system once said abnormal reading is corrected.

6 Claims, 3 Drawing Sheets

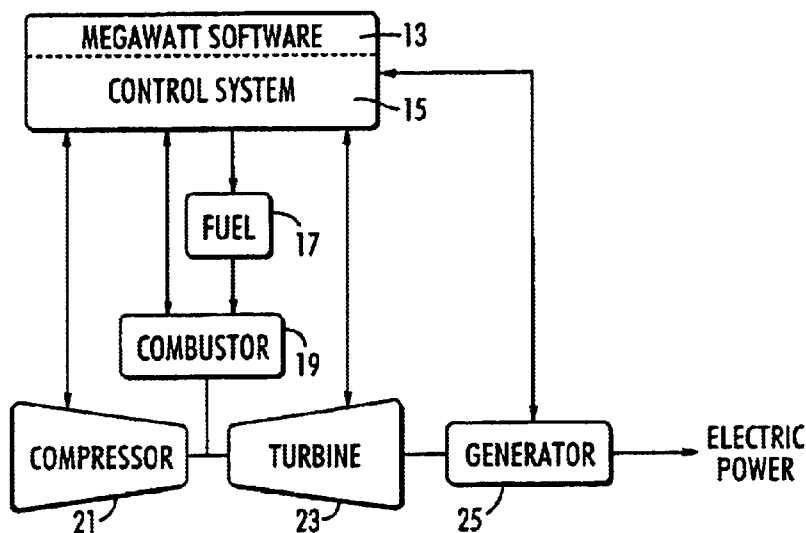

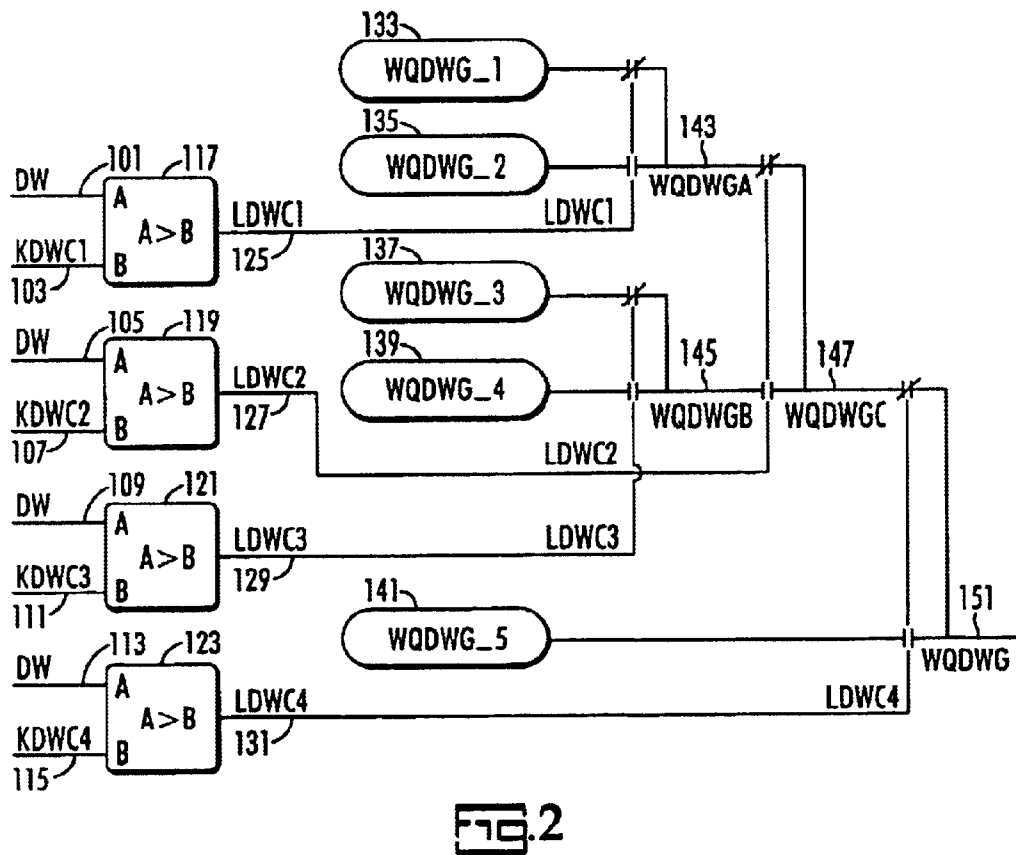
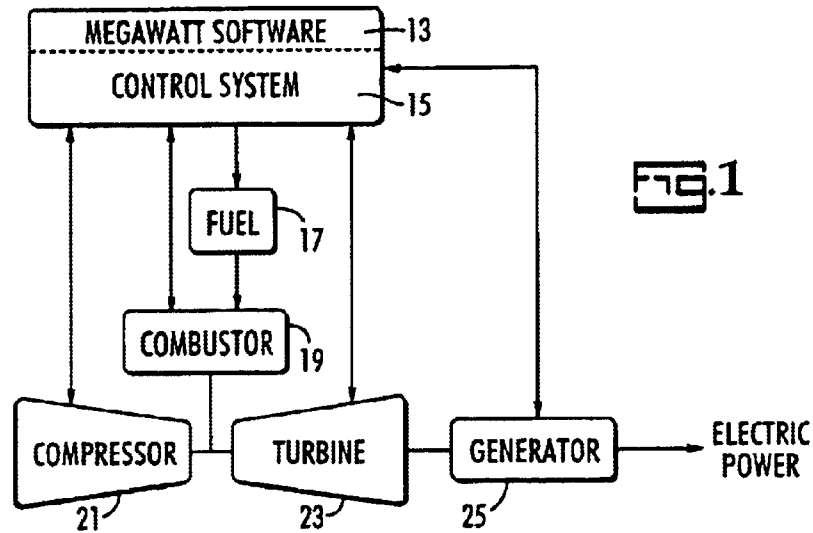

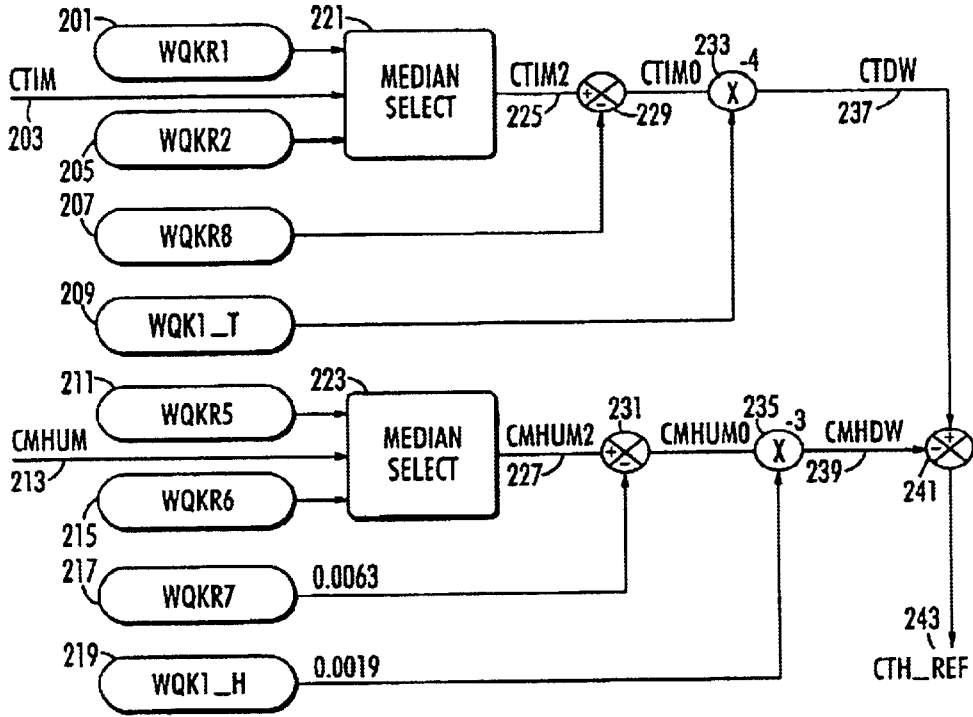

FIG. 3

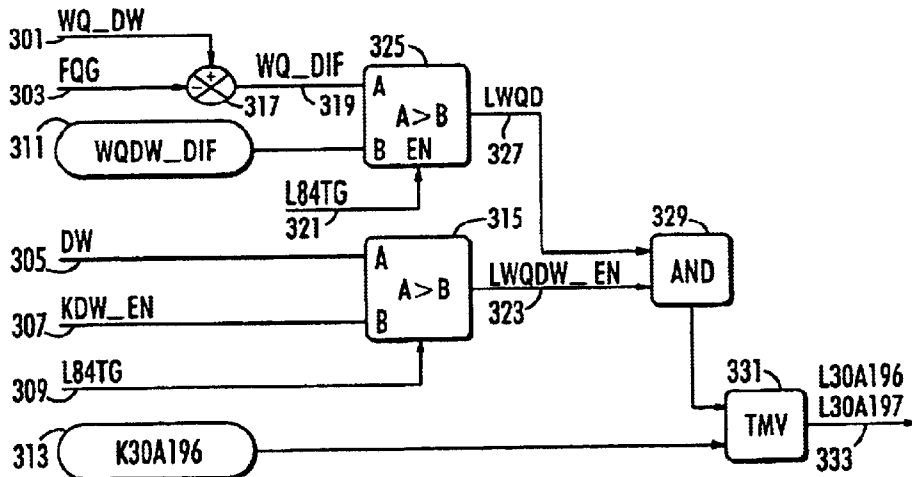
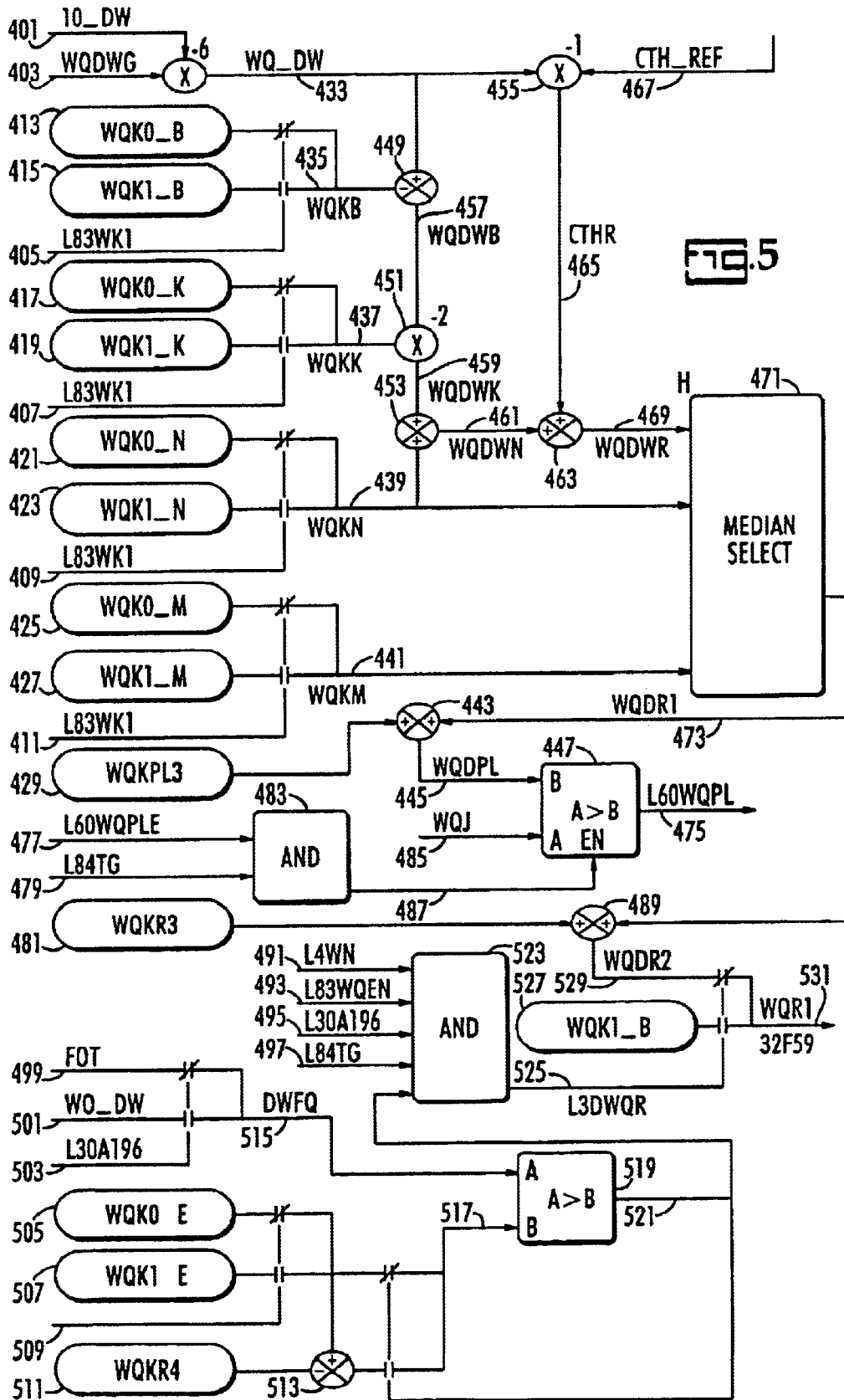

FIG. 4



SOFTWARE SYSTEM FOR VERIFICATION OF GAS FUEL FLOW

RELATED APPLICATIONS

This application claims priority to, and is a continuation-in-part of provisional patent application 60/387,151, filed Jun. 7, 2002, now expired.

FIELD OF THE INVENTION

The present invention relates to a method for providing an independent verification of gas fuel flow which may be used to control water injection flows, which are used to control emissions from a natural gas power plant.

BACKGROUND OF THE INVENTION

As the demand for electricity skyrockets in the United States and the world, government and private industry must uncover and maximize power sources. One of these sources is natural gas.

Origins of methane (CH₄) include conversion of organic material by microorganisms (biogenesis), thermal decomposition of buried organic matter (thermogenesis), and deep crustal processes (abiogenesis). Buoyant methane migrates upward through rock pores and fractures and either accumulates under impermeable layers or eventually reaches the surface and dissipates into the atmosphere. Biogenic methane results from the decomposition of organic matter by methanogens, which are methane-producing microorganisms and which pervade the near surface of the Earth's crust in regions devoid of oxygen, where temperatures do not exceed 97 degrees Celsius (207 degrees Fahrenheit). Methanogens also live inside the intestines of most animals (people included) and in the cud of ruminants such as cows and sheep, where they aid in the digestion of vegetable matter.

Because the methane generated in the subsurface is less dense than the rocks in which it is produced, it diffuses slowly upward through tiny, interconnected pore spaces and fractures, and it can eventually reach the Earth's surface and dissipate into the atmosphere. In places, however, the diffusion of methane is impeded by impermeable rock layers and gas can become trapped in structures. If enough gas accumulates under these impermeable layers, the structures can be drilled and gas can be extracted for use as an energy source.

For natural gas, the cycle begins at gas wells, where gas is extracted from the ground. After processing, the gas is compressed and distributed through pipelines. To generate electricity, fuels such as oil, coal, natural gas, nuclear, hydroelectric and others must be extracted, processed, transported and converted.

Natural gas can be used to generate electricity in many different ways. Natural gas power plants generating more than a couple of hundred megawatts (1 megawatt=1 MW=1 million watts) use the same technology as coal fired power plants. Natural gas is burned to produce heat, which boils water, creating steam which passes through a turbine to generate electricity. Slightly smaller natural gas power plants can use gas turbines to produce electricity. Gas turbines are similar to jet engines and can convert up to half the energy of the natural gas fuel into electricity.

These power plants produce emissions that can be harmful to the environment, and are subject to regulatory control by local, state and national governments. In the case of natural gas fired electricity plants, these emission include Nitrous Oxides (NO_x) and Carbon Monoxide (CO).

One current approach to controlling and monitoring these emissions utilizes a control algorithm and control system, which uses a signal generated from fuel flow transmitters associated with a metering tube orifice. These transmitters are set up in a split-range function; such that the first transmitter measures low gas flows and the second transmitter measures high gas flows, in order to provide accurate flow readings across the full range of gas flow. The transmitters are used to provide readings to a control system, which in turn controls the injection of steam or water into the combustors to meet emissions and operating requirements. The amount of water required is a function of the fuel flow, the fuel type, the ambient humidity and NO_x emissions levels required by the relevant regulations. Transmitters of this type tend to drift and require biannual calibration, at a minimum, to stay within acceptable tolerances.

When the transmitters are miscalibrated, or gas condensate collects in a leg of the fuel flow transmitter, an out-of-compliance event can exist and yet not be detected by the current monitoring system, or a false alarm may be generated.

The present invention is particularly suitable for use with the General Electric SPEEDTRONIC™ Mark IV, Mark V, and Mark VI Gas Turbine Control Systems. The SPEEDTRONIC™ Control Systems are computer systems that utilize microprocessors to execute programs to control the operation of the gas turbine using the transmitter data, sensor inputs and instructions from human operators.

While the above device is a fair representation of the current prior art, there remains room for improvement as defined by the currently-claimed invention.

SUMMARY OF THE INVENTION

It is an object of the present invention to provide a highly accurate system for measuring natural gas fuel flow.

It is a further object of the present invention to generate an algorithm which can be used to detect and control out-of-compliance events.

It is a further object of the present invention to monitor gas fuel flow transmitters and provide notification when gas fuel flow transmitters are out of calibration.

It is a further object of the present invention to utilize an existing megawatt transducer signal to produce a conditioned signal, in the form of a curve, which is compatible with fuel flow scaling.

It is a further object of the present invention to allow for H₂O injection based on a megawatt reference curve for NO_x control when required.

These as well as other objects are accomplished by a computerized system for accurate, independent verification of natural gas fuel flow in order to control H₂O injection flows as said H₂O is injected into a combustion system primarily to control NO_x and CO emissions.

BRIEF DESCRIPTION OF THE DRAWINGS

FIG. 1 illustrates a gas turbine constructed in a well known manner and an associated control system in accordance with the invention.

FIG. 2 illustrates part of the control algorithm of the invention.

FIG. 3 illustrates part of the control algorithm of the invention.

FIG. 4 illustrates part of the control algorithm of the invention.

FIG. 5 illustrates part of the control algorithm of the invention.

DETAILED DESCRIPTION OF THE INVENTION

In accordance with this invention it has been found that a reliable process source, particularly the megawatt transducer, can be utilized for detecting and controlling out-of-compliance events as they relate to gas flow when being used for control of NO_x and CO emissions through a water injection-based system. Various other advantages and features will become apparent from the following detailed description, together with reference to the figures.

The description and figures will utilize a mnemonic nomenclature typical as set forth in Gas Turbine Standard TM-30 and reproduced for clarity in the following Table:

TABLE

Letter	Gas Turbine Origin	Physical Parameter	Type
A	Air	Current, Amperes	
B	Bearing	Vibration	
C	Compressor	Clearance	
D	Driven Load	Differential Pressure	
E	Electrical		
F	Fuel	Frequency	
G	Governor	Stress	
H		Hertz	
I	Intercooler	Impact Press	
J			
K	Combustion		Constant
L	Lube	Force	
M	Extractions	Miscellaneous	
N	Inlet Air Nozzle	Speed	
O			
P	Start Turn Device	Static Pressure	
Q	(Buffers)	Volume or weight flow	
R	Regenerator		Reference, Control
S	Station on Steam	Stroke/Position	
T	Turbine	Temperature	
U	Auxiliary	Utilization	
V	Voltage		
W	Water/Steam	Watts	
X	Exhaust	Ratio	
Y			
Z	(Local Signals)		

By way of illustration, signal "DW" would represent a driven load, in differential pressure, of water or steam, in watts. Similarly, signal "KDWG", would represent a signal related to combustion, driven load differential pressure, water/steam watts and compressor clearance. Other control parameters referred to herein are defined accordingly.

The present invention is specific to a MW reference curve which is based on a megawatt signal (DW) being multiplied by a gain (WQDWG) which is then representative of Total Fuel Flow (FQT). Currently, all water injection flows are derived from fuel flows. The ability to shape the megawatt signal to a fuel flow relationship is an important aspect of the present invention.

The gains are derived by data gathering during the gas turbines's normal operating conditions and with the unit in NO_x compliance using the fuel flow (FQT) as the controlling signal for water injection control. The data is manipulated in accordance with the present invention and the result is a set of gain values that characterize the megawatt signal such that it can be used in place of the fuel flow signal.

The megawatt signal is developed from electrical taps off of the generator output lines and feed back into a megawatt transducer, which converts this voltage into a control signal (DW) that is sent to the control system software.

For the purposes of the present invention the General Electric SPEEDTRONIC™ Gas Turbine Control System is used for describing the invention. It would be apparent to one of ordinary skill in the art that the control parameters could be used from any gas turbine control system and that the present invention would be usable therewith.

FIG. 1 illustrates a gas turbine constructed in a well known manner and an associated control system in accordance with the invention. A gas turbine 23 is drivingly connected to a compressor 21. A fuel controller 17 introduces fuel into the combustor 19, which is then introduced into the turbine 23 along with the products of the compressor 21. The turbine 23 drives a generator 25 which produces electrical power.

The control system 15 of the preferred embodiment is a General Electric SPEEDTRONIC™ Gas Turbine Control System. However, it should be appreciated by those skilled in the art that the present invention may be used with a variety of control systems as well as differing versions of any one manufacturer's control system. This system is designed to fulfill all requirements of operating a gas turbine electric power generating system. The control system performs many functions, such as: fuel, air and emissions control; sequencing of turbine fuel and auxiliary for start-up, cool down and shutdown; monitoring of all turbine, control and auxiliary functions; protection against unsafe and unlawful operating conditions; and providing feedback to human users.

The General Electric SPEEDTRONIC™ system uses signals generated from sensors located in the combustor 19, compressor 21 and turbine 23 as input variables for its algorithms. Specifically, for emissions control, the SPEEDTRONIC™ system uses a signal generated from only one source: fuel flow transmitters that are associated with a metering tube orifice. These transmitters are set up in a split-range function, such that the first transmitter measures low gas flows and the second transmitter measures high gas flows, in order to provide accurate flow readings across the full range of gas flow. This reliance on a single source can result in errors which can cause the control system 15 to indicate that it is in compliance with applicable government regulations, even though it is not.

As there exists only one source of data which is sent to the control system 15 for fuel flow evaluation, an actual fuel flow error can possibly be created due to the single transmitter function and its effect directly relates to the NO_x Emissions Monitoring as reported to the state.

Several problems can exist with the transmitter, independently, that will cause emissions to be incorrectly reported. An error in the calibration of the transmitter or an offset to a properly calibrated transmitter, such as gas fuel condensate in one leg of the transmitter, can report a lower fuel flow. This in turn, due to how the GE algorithm is designed, will not cause or show out of compliance alarms by the emissions monitoring system unless a continuous emissions monitoring system is in use.

The megawatt module 13 is a modification to the SPEEDTRONIC™ system to allow for water injection based on a megawatt reference curve for NO_x control when required. The addition of a second and independent data source, other than the gas fuel flow transmitter function, can be used as a backup reference for mitigating any single source data problems. Since the megawatt transmitter is an extremely accurate data source, requiring in most cases no recalibration year after year of unit operation, it is an excellent comparison for the gas fuel flow transmitter.

5

The megawatt module **13** is designed to allow the units to operate as in the past in compliance to NO_x emissions as permitted for each specific site and does not change or modify the existing GE algorithm. By now monitoring the variances, between the existing gas fuel flow and newly installed megawatt reference signal, the control system **15** is capable of detecting and transferring NO_x water injection control from the existing GE algorithm to the megawatt algorithm.

This megawatt module **13** utilizes the existing megawatts transducer signal in the SPEEDTRONIC™ system to produce a conditioned signal that is compatible with fuel flow scaling, in pounds per second (#/sec). The megawatt module **13** also adds: two operator alarms and the ability of automatically switching between megawatt and fuel flow curves; the ability to start and stop the unit while functioning on the megawatt control curve; and the ability to perform maintenance on the NO_x fuel flow system while the unit is in-service with the megawatt function in control and manual curve compensation through the use of one control constant that affects both Fuel and megawatt curves.

With reference now to FIG. 2, part of the control algorithm of the invention is illustrated wherein control constants are used at different times of the slope of the megawatt reference curve. The signal DW **101**, **105**, **109**, **113** is compared to control constants KDWC1 **103**, KDWC2 **107**, KDWC3 **111**, KDWC4 **115**. The comparison code **117**, **119**, **121**, **123** outputs Boolean values LDWC1 **125**, LDWC2 **127**, LDWC3 **129**, LDWC4 **131**. The value LDWC1 **125** is then used to determine which of the two constants, WQDWG_1 **133** or WQDWG_2 **135** proceeds to the next comparison and is designated WQDWGA **143**. The value LDWC3 **129** is then used to determine which of the two constants WQDQG_3 **137** or WQDQG_4 **139** proceeds to the next comparison and is designated WQDWGB **145**. The value LDWC2 **127** is used to determine which of the resultant constants, WQDWGA **143** or WQDWGB **145** proceeds to the next comparison and is designated WQDWGC **147**. The value LDWC4 **131** is used to determine whether WQDWGC **147** or control constant WQDWG_5 **141** proceeds from the control block and is designated WQDWG **151**. This is the gain to be used based on a range in a megawatt scale.

With reference now to FIG. 3, another part of the control algorithm of the invention is illustrated. Constant controls WQKR1 **201** and WQKR2 **205** are fed into a median select operator **221** along with a compressor temperature inlet value **203**. The resultant median value is designated CTIM2 **225** and is scaled **229** with a constant WQKR8 **207** to result in the value CTIM0 **230**. CTIM0 **230** is then multiplied with a gain constant WQK1_T **209** to result in a positive value CTDW **237**.

Additionally, constant controls WQKR5 **211** and WQKR6 **215** are fed into a median select operator **223** along with a relative humidity value **213**. The resultant median value is designated CTHUM2 **227** and is scaled **231** with a constant WQKR7 **217** to result in the value CMHUM0 **230**. CTIM0 **230** is then multiplied **235** with a gain constant WQK1_H **219** to result in a value CMHDW **239**. CMHDW **239** is then subtracted **241** from CTDW **237** to result in temperature reference CTH_REF **243**.

With reference now to FIG. 4, another part of the control algorithm of the invention is illustrated whereby alarms may be activated. A measurement WQ_DW **301** based on water flow in megawatts is offset **317** with a value FQG **303** to result in a value WQ_DIF **319**. This value is compared **325**

6

with constant value WQDW_DIF **311** if the enable value L84TG **321** is active high, which occurs when the system is operating on total gas as opposed to a mixture of gas and fuel such as diesel. The resulting Boolean value LWQD **327** is sent to an “AND” comparison with a value derived as follows. The value DW **305** comes in through a megawatt transducer and is compared to KDW_EN **307** if the enable value L84TG **309** is active high, which occurs when the system is operating on total gas as opposed to a mixture of gas and fuel such as diesel. The resulting Boolean value is compared in the “AND” comparison **329** and the resultant value is entered into a TMV **331** along with a duration constant K30A196 **313**. If the signal **330** goes into the TMV **331** for longer than the duration constant **313**, then the alarm values L30A196 and L30A197 **333** are sent on to further areas of the system.

With reference now to FIG. 5, another part of the control algorithm of the invention is illustrated. The signal DW **401** is based on actual megawatts and is multiplied **431** with the gain to be used based on a range in the megawatt scale, WQDWG **403** and results in the water flow based on megawatts, WQ_DW **433**. WQ_DW **433** is multiplied **455** with CTH_REF **467** to result in CTHR **465**.

WQ_DW **433** is further offset by the value WQKB **435**, which is either constant WQK0_B **413** or constant WQK1_B **415** depending on control value L83WK1 **405** which comes from the original GE algorithm and is based on high flow versus low flow. The result of the offset is WQDWB **457** is then multiplied by the value WQKK **437** which is either constant WQK0_K **417** or constant WQK1_K **419** depending on control value L83WK1 **407** which comes from the original GE algorithm and is based on high flow versus low flow. This result is WQDWK **459** which is then offset by value WQKN **439** which is either constant WQK0_N **421** or constant WQK1_N **423** depending on control value L83WK1 **409** which comes from the original GE algorithm and is based on high flow versus low flow. The resultant offset WQDWN **461** is offset **463** with value CTHR **465** and fed into a median select operation **471**. Also fed into the median select operation **471** is value WQKN **439** and value WQKM **441**, which is either constant WQK0_M **425** or constant WQK1_M **427** depending on control value L83WK1 **411** which comes from the original GE algorithm and is based on high flow versus low flow.

The output from the median select **471** is WQDR1 **473** is offset with constant value WQKPL3 **429** and the result WQDPL **445** is a protective limit fed into a comparison **447** with WQJ **485**, which is the actual flow based on flow meters in the fuel injection line. This comparison is enabled **467** by the result of an “AND” comparison between GE controls L60WQPLE **477** and L84TG **479**. The result L60WQPL **475** may be used in the control algorithm at a further time.

The control constant WQKR3 **461** is offset with WQDR1 **473** to result in a master value WQDR2 **529**. This master value or a constant equaling zero WQDW_Z **527** is then output as the water ratio input WQRI **531** which defines how much H₂O is injected into the system. The decision between WQDW_Z **527** and WQDR2 **529** is made based upon the following derivation which results in control value L3DWQR **525** which is used to promote value WQDW_Z **527** or WQDR2 **529**.

Total fuel flow is represented as FQT **499** and the water flow equivalent in MW is WQ_DW **501**, and alarm condition L30A196 **333** is used to promote either FQT **499** or WQ_DW **501** to value DWFQ **515**. DWFQ **515** is compared to the resultant of constants WQK0_E **506** or

WQK1_E 507 based upon a value L83WK1 509 from the GE subsystem. The resulting value is offset 513 with constant WQKR4 11 and compared with DWFO 515, with the resultant 521 placed in an "AND" comparison with a master permissive from the GE algorithm L4WN 491, a GE water protection value L83WQEN 493, the alarm signal L30A196 333 and the total gas Boolean L84TG 497 to result in L3DWQR 525, which is the control to determine the final output WQRI 531.

The use of GE variable WQRI 531 is crucial to the invention, as WQRI 531 is not used in the GE algorithm and is constant at zero. This enables the megawatt algorithm to match existing GE control constants, so that if the manufacturer changes the value of the GE constants, no recoding of the invention algorithm is necessary. Also, as many jurisdictions mandate the use of GE-compatible algorithms, this use of a previously unused GE variable (WQRI 531) allows the use of the invention without compromising GE compatibility.

It would be apparent to one of ordinary skill in the art that any data transmission herein can be recorded by a digital storage medium as known in the art.

It is thus seen that this invention provides a highly accurate means of detecting and controlling variations in the water injection process, traditionally based on process fuel flow, that is used in controlling the gas turbine's water injection for meeting Federal and State regulatory limits on NO_x and CO emissions per the issued site license in such a manner that out-of-compliance fines are highly unlikely to be incurred.

As the above description is exemplary in nature many variations will become apparent to those with skill in the art. Such variations however may be embodied within the spirit and scope of this invention as defined by the following appended claims.

What is claimed is:

1. A method for controlling a computerized system for accurate, independent verification of natural gas fuel flow in order to control H₂O injection flows as said H₂O is injected into a combustion system to control emissions, comprising:
 - receiving gas turbine control parameters from a gas turbine control system;
 - receiving control parameters from a megawatt transducer; calculating values based upon readings from said control system and said megawatt transducer;
 - comparing said values to a megawatt reference curve; detecting an abnormal reading;
 - starting a timing sequence during which said reading is monitored;
 - transferring NO_x and H₂O water injection control to a megawatt module at completion of said timing sequence;
 - alerting operator of said transfer;
 - allowing for return of control to said gas turbine control system once said abnormal reading is corrected.
2. The method for controlling the computerized system of claim 1, further comprising performing maintenance of the NO_x fuel flow system while said system is being utilized.
3. The method for controlling the computerized system of claim 1, further comprising manual curve compensation through the use of one control constant for offset capabilities.
4. The method for controlling the computerized system of claim 1, further comprising automatically switching between megawatt and fuel flow curves.
5. The method for controlling the computerized system of claim 1, further comprising the utilization of a non-utilized data point in the GE algorithm.
6. The method for controlling the computerized system of claim 1, wherein data is recorded.

* * * * *